





# WRIGLEYS AFTER EVERY MEAL

affords benefit as well as pleasure. Habitual exercise for the teeth and a spur to digestion. A long-lasting refreshment, soothing to nerves and stomach.

Old Faithful's Antiquity... The Great American... SEALED TIGHT KEPT 'RIGHT' WRIGLEYS SPEARMINT PERFECT GUM



## Strength and Energy this easy way

Simply drop a cake of Yeast Foam in a glass of water; stir for five minutes; stir; let settle and drink the milky water, including the white precipitate. Or, if you prefer, eat the cake with a cracker at a piece of butter.

Easy, simple, palatable. Yet you get the full tonic value of marvelous yeast plant.

MONARCH Breakfast COCOA

Ask your Shoe Dealer for Shoes with USKIDE Soles

For Pimply Skin Peterson's Ointment

# RADIO

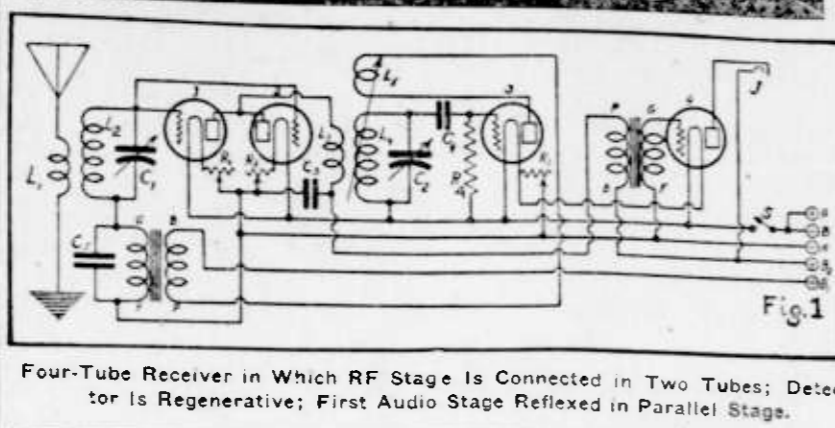

Four-Tube Receiver in Which RF Stage Is Connected in Two Tubes; Detector Is Regenerative; First Audio Stage Reflexed in Parallel Stages.

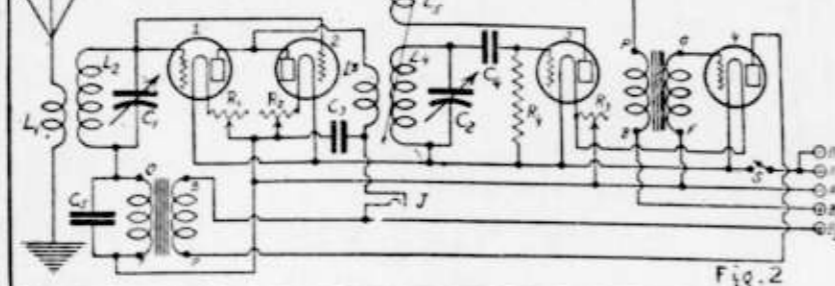

Diagram Showing Same Circuit as That in Fig. 1, Except That the Second Audio Stage is the Reflexed One, Instead of the First.

By SIDNEY E. FINKELSTEIN, in Radio World.

For the fan who has made many sets... The first circuit (Fig. 1) consists of a stage of tuned radio-frequency amplification, with its two tubes connected in parallel, a regenerative detector, the first stage of audio reflexed in the parallel-connected tubes, the second stage of audio being "solo."

Two Audio Stages Employed. As the test is one for reducing the overload, if any, two audio stages must be employed.

To Use Neuroformer in Your Single-Tube Set. Here is R. D. hook-up which uses a unit the same as a radio frequency transformer in the neurodyne set.

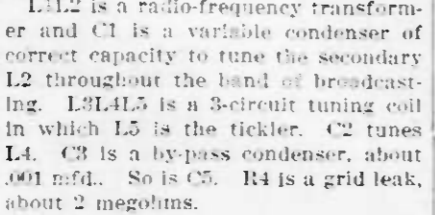

Using Unit Same as Radio Frequency Transformer in Neurodyne Set.

Fit Your Binding-Post Panel Before Mounting. While the appearance of the back of the radio cabinet is not considered important, it is a satisfaction to be able to show your friends a careful workmanlike job of a binding-post panel that fits snugly into the oblong hole cut in the back of the cabinet.

Bottled Wireless for Radio Communication. The latest marvel in the field of radio communication is what the British newspapers call "bottled wireless."

Battery Lore. When charging a battery, always open the vent caps so that the gas can escape.

Battery Causes Fading. Fading of distant stations may be caused at the receiving end through a slight drop in the voltage of the A or B battery.

Tube Sockets. Have all tubes resting properly in sockets. See that the springs are "springy," and that they exert enough upward pressure to keep the bulbs tight against the bayonet lock of the socket.

## Two Essentials of Sweet Clover

For Soil-Building Purposes It Supplies Organic Matter and Nitrogen.

When sweet clover is grown solely for soil-building purposes the question often arises as to when one should cut it under. As a fertilizer, sweet clover furnishes two essentials of a good soil—organic matter and nitrogen.

Tests for Nitrogen. "In one experiment," says Professor Willard, "we sowed the clover with the cuts on April 8, 1927. The same fall after the cuts were harvested we began analyzing the plants—roots and stems—for nitrogen.

Tests Worth Remembering. The above statements, based as they are upon carefully conducted tests, are worth remembering.

Harvesting and Storing Navy Beans for Winter. Navy beans should be harvested and threshed as soon as ready and if infested with bugs they may be treated by one of several methods.

Birds Control Insects in Garden and Orchard. Set the birds up to housekeeping and they will work for you—that, in brief, is the idea conveyed in a news letter from the United States Department of Agriculture.

Alfalfa Crop Improved by Cutting in the Fall. Alfalfa will stand the winter better and give larger yields of hay the next season if it is cut in the fall in time to permit a growth of at least one foot.

Seeding Clover in Fall. A few farmers make a practice of sowing unclarified sweet clover seed late in the fall just before the ground freezes up.

Value of Fodder Corn. The value of fodder corn varies with the amount of water in it. In humid sections it is likely to have so much water in it that one has some difficulty in keeping it.

Supply of Manure Limited. While manure is not a balanced plant food, nevertheless it should all be saved and applied economically.

## Cleaning Machines Remove Most Weeds

Table Shows High Degree of Purity Found.

The Vermont experiment station points out in a recent bulletin that a farmer might as well expect all-wool garments when he buys a cheap suit as high-class seed when he pays a cheap price.

The cleaning processes of the Mc seed houses take out the largest percentage of weed seed and leave the seed comparatively clean, remarkably so compared with its original condition.

Table showing Seed Guaranty and Purity Found for various crops like Alfalfa, Barley, etc.

Trimming Bull's Feet to Prevent Various Evils. Bulls kept in close quarters with little exercise frequently develop long hoofs.

Safe. Accept only "Bayer" package which contains proven directions. Handy "Bayer" boxes of 12 tablets.

Children Cry for Fletcher's CASTORIA. MOTHER—Fletcher's Castoria is especially prepared to relieve infants in arms and children all ages of Constipation, Flatulency, Wind Colic and Diarrhea; allaying Feverishness arising therefrom, and, by regulating the Stomach and Bowels, aids the assimilation of Food; giving natural sleep.

Now Go to Africa. Sightseeing in Africa has become a late fad as a result of the recent visit of the prince of Wales to the "dark" continent.

Fastina Zappi. Faustina Zappi was the daughter of a painter, Carlo Mazzati, and wife of Gambastina Zappi, who was born in 1908 and died in 1919.

For sweet dough set your sponge with Yeast Foam. The wife who is a good bread maker is a real helpmate for the bread winner.

Send for free booklet "The Art of Baking Bread". Good bread is the pride of the thrifty bride.

Northwestern Yeast Co. 1730 North Ashland Ave. Chicago, Ill.

## The Old Standby in a New Dress

—the same dependable remedy that over a period of more than fifty years has been found so reliable in the treatment of catarrh and diseases of catarrhal nature.

PE-RU-NA TONIC. The Original and Reliable Remedy for Catarrh.

It is necessary for manufacturers to have on hand 250,000,000 sacks yearly to handle the nation's demand for cement.

Japanese goldfish cultivators use open-air ponds, not tubs within doors, as do fanciers in America.

Will power works best when it agrees with the notions of the majority. It's a poor watchmaker that is unable to make a go of it. Life is not victory, but battle.

Babies Doing Better. The 1925 baby got off to a good start, all but three of the twenty-five states in the registration area having lower infant mortality rates last year than in 1923.

Going Too Far. When the nutrition experts begin to prove something about the quality of pies by experiments with rats they are carrying their nutrition experiments just a little too far.—Public Ledger.

Seeding Clover in Fall. A few farmers make a practice of sowing unclarified sweet clover seed late in the fall just before the ground freezes up.

Value of Fodder Corn. The value of fodder corn varies with the amount of water in it. In humid sections it is likely to have so much water in it that one has some difficulty in keeping it.

Supply of Manure Limited. While manure is not a balanced plant food, nevertheless it should all be saved and applied economically.

Farm Hints. Seed corn should never be taken from plants that lodge. Much of the value of manure is lost by weathering and leaching.

The wife who is a good bread maker is a real helpmate for the bread winner.

Send for free booklet "The Art of Baking Bread". Good bread is the pride of the thrifty bride.

Northwestern Yeast Co. 1730 North Ashland Ave. Chicago, Ill.

# GLAD TIDINGS SALE

## 7 BIG BARGAIN DAYS

Sale Starts Saturday, October 17th,  
Ending Saturday, October 24th

A wonderful sale, wonderful new merchandise; but the wonder of wonders is the values. Come, come every day. Meet your friends here.

No woman within shopping distance should fail to take advantage of the savings this big event brings.

Watch for the big double page colored poster. It's full of the biggest Fall and Winter bargains ever offered in this community.

We buy Potatoes, Eggs, Beans and other Farm Produce at highest market prices.

### The Poull Mercantile Co.

Store Open Saturday Evening WEST BEND, WIS. Store Open Saturday Evening

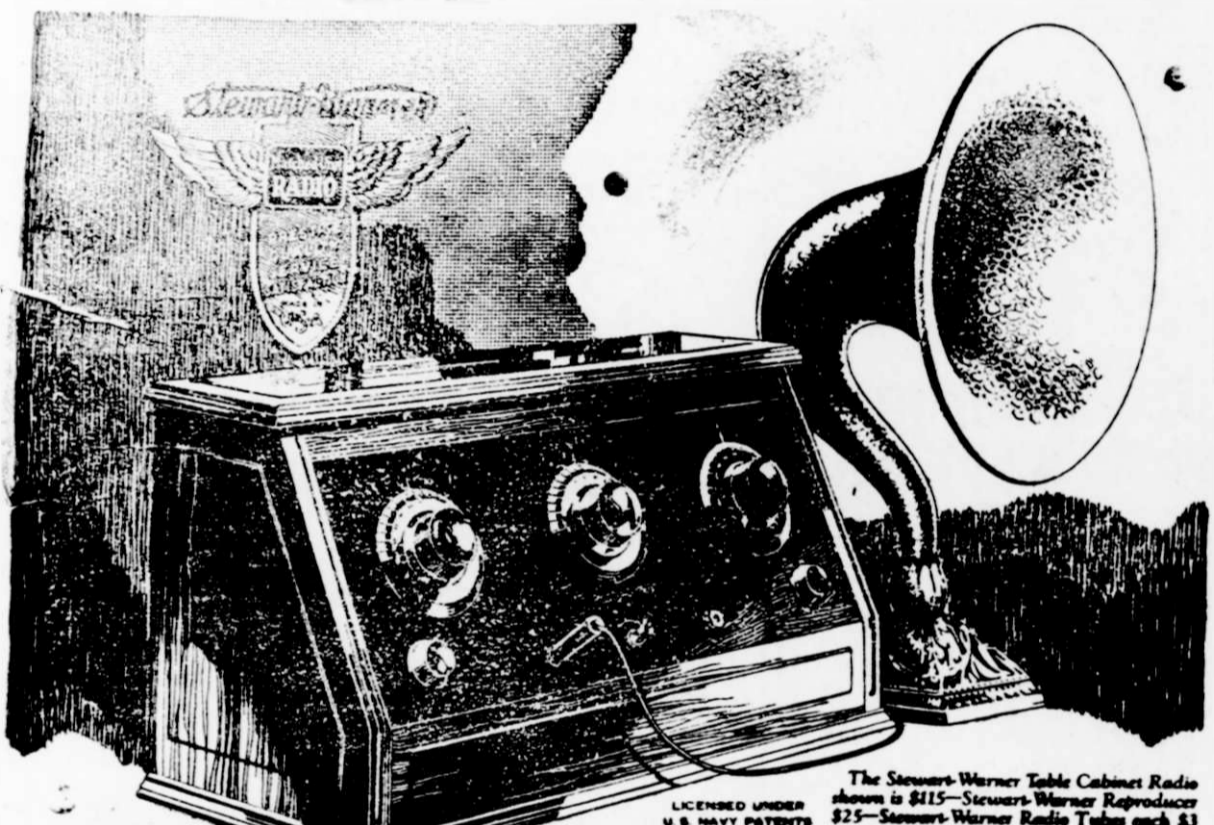

### Stewart-Warner Matched-Unit Radio

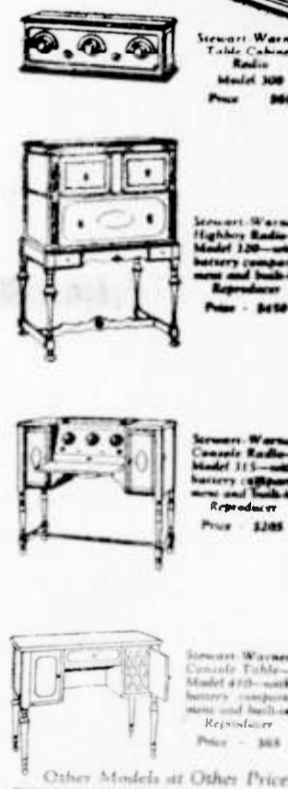

THE real joys of Radio come to those who own the best. And the experienced fan knows that the "best" in Radio now means the Stewart-Warner. Every unit in Stewart-Warner Radio is not only perfect in itself, but also accurately matched for perfect working unison with every other unit.

The Matched-Unit idea—a Stewart-Warner achievement—makes this Radio do the things you have always wanted a Radio to do.

Let us show you the wonderful Matched Unit Radio. We will relieve you of all technical details and give you, through our service, complete radio satisfaction.

## Service Motor Co., Kewaskum

**NEW FANE**  
Adolph Heberer was a business caller at Kewaskum Saturday afternoon. Mr. and Mrs. Frank Ehnert spent Sunday with the August Hoffmann family at Lake Seven.  
Mr. and Mrs. Milton Ehnert and daughter Arleigh spent Sunday with Mr. and Mrs. William Berres at Oshkosh.  
Mr. and Mrs. Charles Bach and family and Mr. Roepert of Milwaukee spent Saturday afternoon with Mr. and Mrs. Frank Ehnert.  
Mr. and Mrs. Adolph Heberer and family attended the birthday party at William Heberer's Saturday evening. The occasion being Mrs. Heberer's birthday.  
The St. John's Y. P. S. met on Friday evening, October 16 at the school. On October 31, there will be a Halloween party. Lunch and candy will be served.  
Subscribe for the Statesman NOW.

**NORTH ELMORE**  
Jacob Conrad is seriously ill at his home with pleurisy.  
Leo Feuerhammer is employed at the Henry Feuerhammer home.  
Mr. and Mrs. Henry Feuerhammer were business callers at Milwaukee on Friday.  
Henry Feuerhammer purchased a new Essex coach from Cornelius Schli at Ashford.  
Mrs. John Kludt spent Tuesday afternoon with her parents, Mr. and Mrs. John Senn.  
Miss Mildred Sabisch spent Friday and Saturday with her grandmother, Mrs. Christ Becker at Elmore.  
**TOWN SCOTT**  
Mrs. Louis Vorpahl Sr. and Mrs. Charles Weinreich Sr. and son Fred spent Thursday afternoon with Mr. and Mrs. John Vorpahl.  
The following spent Sunday evening with Mr. and Mrs. John Vorpahl: Mr. and Mrs. Alfred Radolph, Mrs. Chas. Weinreich Sr., Wm. Edward and And. Vorpahl.  
Subscribe for the Statesman NOW.

**Omar Khayyam.**  
Omar Khayyam was a poet and an astrologer, but it was as a mathematician that he made his most noteworthy contributions to science. He attempted a systematic classification of types of equations of the first three degrees. He knew the rule for expanding a binomial for positive and negative powers, a rule afterward perfected by Newton as the binomial theorem.  
**The Mosquito.**  
Outside of his fellow man, the mosquito is the most dangerous living creature to man as more people die each year as a result of its bite than by the ravages of any other animal. The cobra snake of Indian ranks second in the number of people killed, but this is largely due to the superstitious character of the natives of India, who are afraid to kill the snakes.  
**Taking a Mean Advantage**  
It is hard of a hustler to do a thing while the efficiency expert is waiting for a blueprint.

### CAMPBELLSPORT

Miss Esther Curran spent Monday with relatives at Fond du Lac. Born, a baby girl to Mr. and Mrs. Andrew Saefeld on Wednesday.  
Mrs. John W. Schaefer of Kewaskum spent Friday with relatives here. Roland Urban, Charles Backus and sister Alice spent Saturday at Milwaukee.  
Frank Cole and family of Lomira spent Sunday with Mr. Cole's mother here.  
Herman J. Paas and family spent Monday evening with friends at Fond du Lac.  
Mr. and Mrs. Rudolph Kasberg left for Geneva, where Mr. Kasberg has employment.  
Mr. and Mrs. Leo Becker and daughter spent Friday with relatives at Brownsville.  
Vincent Welch, Clem Bowen and Earl Headings left Friday on a hunting trip to Canada.  
Mr. and Mrs. P. A. Kraemer and daughter Estelle spent Sunday with relatives at Calumet.  
Mrs. Rheinhold Weber and daughter Eloise visited with relatives at Fond du Lac Monday.  
Miss Daisy Ferber is spending the weekend at Oshkosh and attending the teachers' convention.  
Mrs. Henry Braun and son Nicholas attended the funeral of Charles Mielke at Fond du Lac Friday.  
Mr. and Mrs. W. J. Schill and daughter of Lomira visited the H. A. Weiske family here Wednesday.  
Harry Backus and Frank Dory of West Allis spent Wednesday here at the home of the former's parents.  
Max Glass, who underwent an operation on his tonsils at Milwaukee, came home Monday to spend a week.  
Herman Meyering and Richard Mijares of Milwaukee were Sunday visitors at the Moritz Weasler home.  
The Ladies Aid of the Methodist church was entertained at the home of Mrs. John Vetsch on Wednesday afternoon.  
Mr. and Mrs. Wm. Harris who have made their home on the Pflatter Bros. farm, will make their future home in Chicago.  
The marriage of Miss Mary Senn of here to John Kludt of Hartford took place at Menominee, Mich. on Saturday, September 26.  
Mrs. Ray P. Scholler and son Jay left Saturday for their home at La Crosse after spending two weeks with her parents Mr. and Mrs. John H. Paas.  
The members of the New Casual branch of Catholic Knights of Wisconsin will hold their monthly meeting on Sunday after high mass at the St. Matthew's school hall.  
Mr. and Mrs. John Thompson and daughters Marie and Vivian, Nolan and Frances Heffling of Fond du Lac visited a few days this week at the Philip Hausner home.  
George McEvoy and sister Addie, Miss Genevieve Reimer, Charles Miritz and family, Louis Luelke and family, Mr. and Mrs. William Ahland, son Ben, and daughter Agnes, William Reilly and family and John Clark spent Wednesday at Fond du Lac.  
Mr. and Mrs. Jacob Petri and son William arrived from Rheinfalls, Germany Monday and are visiting with Mr. and Mrs. M. R. Boeckler. Mr. Petri is a nephew of Mr. Boeckler. After a visit here with relatives the Petri family will make their future home in America.

### CLASSIFIED ADS

Our rates for this class of advertising are 5 cents a line, no charge less than 25¢ accepted. Count six words to the line. Cash or guaranteed stamps must accompany order.

**For Sale.**  
FOR SALE—Five shares stock Farmers & Merchants State Bank, Kewaskum, Wis. Assessment paid.—\$75 per share. Address "K" Statesman Office, Kewaskum, Wis.—Advertisement.

FOR SALE—Black work horse, eight years old and weighing 1350 pounds. Inquire of Aug. C. Voesks, R. 5, Kewaskum, Wis.—Advertisement 8 8 tf.

FOR SALE—The Wittig store and saloon property in Fillmore. Also 15 acres of land. Price is right. For further particulars call on J. H. Klossig, Kewaskum or E. W. Jaehning, Port Washington.—Advertisement, 9 19 tf.

FOR SALE—Eight room house in the village of Kewaskum, good big garden and good buildings. For further particulars inquire of Joseph Schoofs, R. 3, Kewaskum, Wis.—Advertisement, 10 3 4.

FOR SALE—Must be sold to close an estate, the former Victoria Kohler farm, consisting of 120 acres of choice farm land, good buildings. Farm located one half mile west of St. Killian, Fond du Lac county, Wis. Inquire of Peter J. Flasch, St. Killian, Wis. or B. H. Rosenheimer, Executor, Kewaskum, Wis.—Advertisement, 10 17 2t.

### BOLTONVILLE

Mrs. M. Lambrecht suffered a paralytic stroke on Monday.  
Miss Marjorie Woog is ill at her home here with scarlet fever.  
Mr. and Mrs. W. Frauenheim were Kewaskum callers Wednesday.  
Mrs. Jack Schoetz is spending some time with relatives at Chicago.  
Miss Celia Krell is spending some time with the H. Laatsch family.  
Mrs. Herman Becker entertained the Ladies Aid on Wednesday afternoon.  
J. Frohman of Waubesa spent a few days at the Edw. Frohman home here.  
Mr. and Mrs. O. Koth spent Sunday with the A. Stautz family at West Bend.  
Mr. and Mrs. O. Krahn of Batavia spent Sunday at the George Hiller home.  
Mr. and Mrs. Arnold Stautz of West Bend spent Sunday evening with the C. Stautz family.  
Miss Cora Marshman returned home from Milwaukee Tuesday, after spending the past week there.  
Mrs. Paul Belger entertained a few friends on Tuesday evening, it being her birthday anniversary.  
Mr. and Mrs. William Donath attended the funeral of the former's sister at Milwaukee Monday.  
Quite a few from here attended the funeral of Mrs. C. Oeder, which was held at Batavia on Tuesday afternoon.  
Mrs. William Enright returned home Sunday from the Dr. Urkharit hospital at West Bend, greatly improved in health.  
Mr. and Mrs. C. Stautz of Milwaukee, Mr. and Mrs. C. Stautz and daughter and Mr. and Mrs. C. Eisentraut and family spent Sunday with the O. Schneider family near Batavia.

## Stylish New Fall Millinery

Our large showing of best quality Millinery at popular prices is winning a growing patronage. You are invited to inspect this department and profit our low prices.

### 5000 BUSHELS OF POTATOES WANTED

## New Fall Shirts for Men

Just received a large selection of New Dress shirts for Men in the new colors. These shirts are large and roomy, fast color and usually sell for more than prices, from \$2.00 to \$3.50.

### FRESH EGGS WANTED

### Shoes

You can get the biggest values for your money in shoes when you buy "Star Brand" Shoes for Men, Women, Boys and Girls. We have many new styles and guarantee foot comfort.

### HAND PICKED APPLES WANTED

We pay cash for Farm Products

## PICK'S

WEST BEND DEPARTMENT STORE

We pay cash for Farm Products

Service and Satisfaction Guaranteed

### Condensed Statement of the Condition of the

## Farmers & Merchants State Bank

Kewaskum, Wisconsin

at the Close of Business Sept. 28th, 1925

**RESOURCES**

|                                       |                     |
|---------------------------------------|---------------------|
| Loans and Discounts                   | \$125,254.86        |
| Overdrafts                            | 34.88               |
| U. S. and Other Bonds                 | 20,642.69           |
| Banking House, Furniture and Fixtures | 9,450.00            |
| Cash and Due from Banks               | 26,058.87           |
| <b>Total</b>                          | <b>\$181,440.52</b> |

**LIABILITIES**

|                   |                     |
|-------------------|---------------------|
| Capital Stock     | \$ 25,000.00        |
| Surplus           | 1,200.00            |
| Undivided Profits | 3,401.72            |
| <b>DEPOSITS</b>   | <b>151,838.80</b>   |
| <b>Total</b>      | <b>\$181,440.52</b> |

*"A Community Bank"*

## Electrical Supplies of All Kinds Carried

We Specialize in House Wiring and Installation

## LEO SKUPNIEWITZ

Successor to Harold Petri  
KEWASKUM, WISCONSIN

Funeral Parlors at 2326 Center St. Phone--Kilbourn 19

## Frank A. Zwaska UNDERTAKER

Especially Equipped to Ship Bodies from Hospitals  
MILWAUKEE, WIS.

**PERUN**

The Most Successful Treatment of the Century for CATARRH

Tablets of Liquid Sold Everywhere

**History of Staring.**  
History verifies the fact that the practice of staring, which came into fashion in England in the reign of Queen Elizabeth, was invented by a Spanish woman about the middle of the fifteenth century. She wished to hide a blotch on her neck with an enormous veil.

**Mementoes for Widow**  
During an incantation over the body of a Japanese sailor, who was accidentally killed at Millborough, England, another member of the crew was granted permission to take the hair and toenails of the dead man to the widow in Japan.

**Position of the Heart**  
Medical authorities say that it is possible for human beings to have their hearts on the right side of their bodies—in fact, it is known that there are some people living today who have this organ on the right side.

**Shocked the Cat**  
Wife (of her husband)—She has an awful temper, and even my black cat has gone white-haired since I married him.

**Ah, That's the Rub!**  
Chicago girl says she will marry the man who pays her father's debts, but applicants had better find out who made the debts.—Columbia Record.

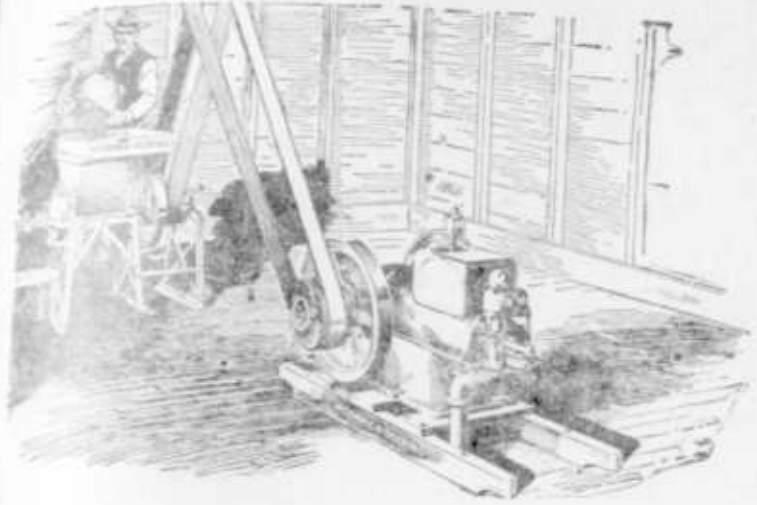

**McCORMICK - DEERING**  
A Name that Means Much on Farm  
Engines and Feed Grinders!

McCormick-Deering Engines and Grinders work together in perfect harmony—the harmony of equal effort. McCormick-Deering Engines have long been leaders in their field. The same is true of McCormick-Deering Grinders. We have a complete stock of both machines and can furnish you either or both in sizes and styles perfectly suited to your special power and feed requirements. Many of our customers have already proved to their own satisfaction the wisdom of grinding their grain for feed; and they are finding many other uses for their sturdy McCormick-Deering Engines, too. You'll find this combination of two excellent machines is a winner—a most valuable investment. May we demonstrate these two machines to you soon?

**A. G. KOCH**  
Kewaskum, Wis.

**ATTEND THE MOVIES**  
Sunday Evening, Oct. 18

Booth Tarkington's  
**"The Turmoil"**  
A Rare Opportunity for Rare Entertainment Offered to You at the Opera House Sunday.

—AND—  
**"Go-Getters" — "Better Than Ever"**  
**COMING!**  
**"AMERICA"**  
Buss & Buss

**GOOD USED CARS**

- 1 Ford Tu-Door Sedan in very good shape, spare tire, special steering wheel, and all other accessories, at **\$495.00**
- One 1924 Ford Coup, also in very good shape, at **\$3.65.00**
- 1 Ford Roadster, in good condition, at **\$150.00**
- 1 Dodge Touring Car, 1919 model, all good tires, at **\$285.00**

**REX GARAGE**  
Phone 3012 Kewaskum, Wis.

**JOHN MARX**  
Groceries, Flour and Feed  
Kewaskum, Wisconsin

**KEWASKUM STATESMAN**  
HARBECK & SCHAEFER, PUBLISHERS  
Entered as second class mail matter at the post office Kewaskum, Wis.  
SINGLE COPIES 5 CENTS  
TERMS—\$2.00 per year; \$1.00 for six months. Advertising Rates on Application.

SAYS:  
"See Mrs. K. Endlich's add elsewhere in this paper."  
"SPARKLES"

**TRAIN SCHEDULE**

**GOING SOUTH**

No. 23—Daily except Sunday..... 7:30 a. m.  
No. 21—Daily..... 9:45 a. m.  
No. 19—Daily except Sunday..... 11:55 a. m.  
No. 22—Sunday only..... 1:15 p. m.  
No. 24—Sunday only..... 3:35 p. m.  
No. 20—Daily except Sunday..... 5:55 p. m.

**GOING NORTH**

No. 26—Daily..... 8:22 a. m.  
No. 12—Daily..... 10:35 a. m.  
No. 16—Daily..... 12:50 p. m.  
No. 25—Daily except Sunday..... 3:10 p. m.

Saturday, Oct. 17, 1925

**LOCAL HAPPENINGS**

—Mr. and Mrs. Roman Smith were Milwaukee visitors last Friday.

—Louis Bath was a business caller at Campbellsport Monday evening.

—Elmo Rosenheimers of Jackson spent Sunday with his parents here.

—Miss Corinne Schaefer spent the week-end with friends in Chicago.

—The first snow fall of the season was experienced here last Friday evening.

—Miss Dorothy Dana of Appleton visited over the week-end at her home here.

—William B. Wells of Chicago transacted business here several days this week.

—Mrs. Erwin Koch and daughters Audrey and Janice were Milwaukee visitors Monday.

—Mrs. John W. Schaefer spent last Friday with the Martin Knicker family at Campbellsport.

—Justice of the Peace William Ferber of Campbellsport was a pleasant village visitor Monday.

—County Superintendent of P. T. Buckley of West Bend visited the school here Wednesday.

—Joseph Brunner and Pat O'Malley of Milwaukee spent over Sunday with Mr. and Mrs. John Brunner.

—Mrs. Augusta Clark and daughter Edith and Mrs. Albert Glander were Milwaukee visitors Saturday.

—Mrs. William Frost was at West Bend Wednesday where she attended the funeral of Mrs. William Colvin.

—The Misses Elizabeth and Magdalene Helgert of Milwaukee spent Sunday with Mr. and Mrs. Otto B. Graf.

—Mrs. George Parker of Highland Park, Ill., was a guest of Mr. and Mrs. William F. Backus last Thursday.

—Mr. and Mrs. Herbert Holtz returned home Monday from their wedding trip through the Eastern States.

—Mr. and Mrs. Fancher Colvin attended the funeral of the former's mother at West Bend Wednesday afternoon.

—Mr. and Mrs. Henry Goetsch and Mr. and Mrs. Carl Dahle of Milwaukee spent Sunday with the Jacob Schlosser family.

—The pupils of the Holy Trinity school enjoyed an informal program Monday afternoon in commemoration of Columbus Day.

—Myron Perschbacher of Appleton spent Saturday and Sunday with his parents, Mr. and Mrs. A. A. Perschbacher and family.

—Mr. and Mrs. D. M. Rosenheimer and family motored to Cedarburg last Sunday where they visited the Henry Wittenberg family.

—Do not fail to attend the 51st anniversary sale at the L. Rosenheimer store on Wednesday, Thursday and Friday, October 21, 22 and 23.

—A. C. Backus of Milwaukee, formerly municipal judge of that city, was the principle speaker at the opening meeting of the fall season of the Presbyterian Men's Club of Fond du Lac, which was held there on Friday evening.

—Mr. and Mrs. William Mc Bray and son Robert of Platteville, Wis., spent Saturday and Sunday with their daughter, Mrs. C. W. Nodoff and family. Mrs. Nodoff and children returned home with them for a week's visit with them.

—Mr. and Mrs. Elmo W. Rosenheimers spent Sunday with relatives at Appleton. They were accompanied here by Mrs. Lay's sister, Miss Ella Wood, who returned here last Friday from a three months' trip through the European countries.

—John Kohn, who was formerly manager of the Kewaskum Opera House, moved his household furniture into the Emil Siegel residence on North Fond du Lac Ave., Thursday. John Van Blarcom and Louis Heister, who rented the Opera House took possession of the same on Thursday.

—Mr. and Mrs. William F. Schultz motored to Milwaukee last Sunday afternoon. They were accompanied there by Fred Rummel and daughter Mrs. C. Whitlatch, who visited some time here. Mr. Rummel and daughter will visit relatives at Milwaukee for a week when they will return to their home in New York.

—Anthony P. Schaefer and family were Chicago visitors Sunday, being called there on account of the death of Mr. Schaefer's uncle, Charles Utes, who died last Friday. Mr. Schaefer and daughter Pearl returned home the same day, while Mrs. Schaefer remained there until Monday to attend the funeral.

—Cedarburg was awarded the 1926 tournament of the Badger Firemen's association, this conclusion was reached at a meeting held at the Republican House at Milwaukee last Sunday. For reason that the Cedarburg Fire Company will celebrate its diamond jubilee next year it has been awarded two tournaments the State and Badger tournneys.

**51st ANNIVERSARY SALE**

Wednesday, Thursday and Friday, October 21, 22, and 23, are the dates set for the 51st anniversary sale held by the L. Rosenheimer firm. This sale unquestionably will not only be the biggest one ever held by the firm, but one of the largest ones ever staged in Washington county. A ten per cent discount will be given on every article sold in the store, on top of all the bargains offered during the three day sale, a discount of 20 per cent will be offered on certain articles. Guessing contests will also be held, the winners of which will be awarded a handsome reward. Large full sheet circulars were printed in this office this week, one of which will be mailed to every home in this community, giving full details of the tremendous bargains offered. Do not fail to read every bit of it, make your selections and go to the store early and do your shopping. The largest crowd that has ever attended any of the sales ever held by the L. Rosenheimer firm is expected to be on hand. Do not forget the day and dates, October 21, 22, and 23.

**SHOTS FIRED AT LINCOLN CAR BELIEVED TO BE OCCUPIED BY RUM RUNNERS ON HIGHWAY 55**

Campbellsport, Oct. 9.—What is thought to be high jackers searching for and attempting to stop cars that might be carrying liquor, has been reported by residents of this vicinity, this week. Monday evening a Lincoln car traveling at a high rate of speed was pursued for some distance by another machine thought to be a Cadillac. As the junction of Highways 67 and 55 was reached, several shots were fired at the Lincoln car. Wednesday evening residents and travelers on Highway 55 reported other cars being pursued. All of the automobiles were high-powered machines and practically all carried Illinois license plates.—Fond du Lac Commonwealth.

**SUBSCRIPTIONS ARE DUE**

This is the time of the year when subscriptions to the Statesman become due. Take a look at the date of your paper, and if you find that your year's subscription is due, a remittance will be appreciated. Some time ago we mailed a number of statements to delinquent subscribers, though a large number responded, there are still a number left to be heard from. We again kindly ask them to remit.

The Publishers.

**FIRE DAMAGES CAMPBELLSPORT WAREHOUSE**

Fire of unknown origin caused damage amounting to several hundred dollars in the warehouse of the Wisconsin Gas and Electric company at Campbellsport Wednesday. A supply of light bulbs and accessories were destroyed. No cause for the fire can be given.

**Keep to the Truth.**  
I have seldom known anyone who deserted truth in matters that could be trusted in matters of importance. Rules

**L. Rosenheimers'**  
**51st ANNIVERSARY SALE**

STARTS WEDNESDAY MORNING OCT. 21st  
ENDS FRIDAY EVENING, OCTOBER 23rd

**Three Money Saving Days for You**

Wednesday, Thursday, Friday,  
October 21, 22 and 23

**Every Article in the Store Is Reduced**

This is our One Big Sale of the Year, and you can rest assured it will be a REAL SALE

**L. ROSENHEIMER**  
KEWASKUM, WISCONSIN

**LOCAL POST ELECTS OFFICERS**

At the regular monthly meeting held in the M. W. A. Hall, last Monday evening the Kewaskum Post of the American Legion elected the following officers for the ensuing year: Post Commander—Dr. Leo Brauchle; Vice-Commander—Wilmet Prost; Adjutant—"Spatz" Miller; Historian—Walter Schneider; Chaplain—Ralph Petri. Sergeant at Arms—August Bilgo.

Among other business transacted at the meeting, was the appointing of an entertainment committee consisting of three members, namely: Spatz Miller, Hubert Wittman and Theo. Schmidt, who will select a play to be staged by the Legion some time in November. It is the intention of the post to give two performances, one in the afternoon and evening, in order to accommodate the large crowds that usually attend these entertainments, and also to give those who come from a far distance a better chance to attend. It is also thought that the post will hold another skat tournament, for which many cash prizes will be given away. The time has as yet not been agreed upon. Plans for holding a big outdoor celebration next summer are also being considered.

**WILL HOLD ANNUAL CHICKEN SUPPER**

The ladies of the Ev. Peace congregation are making arrangements for the annual chicken supper which will be held in the school hall of the church on Thursday afternoon, November 12. That this annual feast will be well attended, if weather conditions will permit is a foregone conclusion. As these suppers prepared by the ladies have gained quite a reputation and are looked forward to by all with keen interest. Don't forget the day and date, Thursday, November 12. More particulars will be published later.

**LOCAL MARKET REPORT**

|                        |              |
|------------------------|--------------|
| Winter wheat           | 1.15-1.25    |
| Wheat                  | 1.25         |
| Barley                 | 55 to 72     |
| Rye No. 1              | 70 to 75     |
| Oats                   | 35 to 38     |
| Eggs strictly fresh    | 42c          |
| Unwashed wool          | 40 to 42     |
| Beans, per lb.         | 4c           |
| Hides (calf skin)      | 15           |
| Cow Hides              | 8c           |
| Horse Hides            | 2.00 to 4.00 |
| Potatoes, hundred lbs  | 1.75-1.85    |
| Live Poultry           |              |
| Old Roosters           | 12           |
| Hens                   | 14-20        |
| Spring Chickens, heavy | 18-19        |
| Leghorns               | 16-19        |
| Ducks                  | 18           |
| Black chicks           | 13-14        |

(Subject to change)

Statement of the Condition of the  
**Bank of Kewaskum**  
Kewaskum, Wisconsin  
at close of business Sept. 28th, 1925

**RESOURCES**

Loans and Discounts..... \$624,398.81  
United States and Other Bonds..... 322,711.30  
Banking House, Furniture and Fixtures..... 14,000.00  
Cash on Hand and Due from Banks..... 138,354.52  
**\$1,099,464.63**

**LIABILITIES**

Capital Stock..... \$50,000.00  
Surplus and Undivided Profits..... 57,474.32  
DEPOSITS..... **991,990.31**  
**\$1,039,464.63**

**Officers and Directors**

A. L. Rosenheimer, President; M. Rosenheimer, Vice-President; A. W. Koch, Otto E. Lay, Directors; N. W. Rosenheimer, Ass't Cashier; H. A. Remmel, Ass't Cashier; M. W. Rosenheimer, Ass't Cashier, B. H. Rosenheimer, Cashier.

**Over Fifty Years of Successful Banking**

**Do You Need Glasses or a New Watch?**

Why suffer from eye strain, when our glasses will give you relief? Let us test your eyes and fit them with glasses, if you need them. Come in today. Our watches will give satisfaction. They are good time pieces.

"Reasonable Prices for Reliable Jewelry"

**MRS. K. ENDLICH KEWASKUM**

**MATH. SCHLAEFER OPTOMETRIST**  
Eyes Tested and Glasses Fitted  
Campbellsport, Wisconsin

**J. N. Smith D. C. CHIROPRACTOR**  
MARX BUILDING  
Office Hours: 9 to 12; 2 to 5; 7 to 9:30  
Monday, Tues., Wednesday, Thurs., Friday  
Special anal. is free at office.  
House calls attended to. Yours for Health!  
Telephone 561

15,254.49  
34.48  
0,642.68  
9,450.00  
3,058.87  
1,440.52

1,000.00  
200.00  
401.72  
138.80  
140.52

All



# Prudence's Daughter

By ETHEL HUESTON

Copyright by the Bobbs-Merrill Co.  
WNU Service

## Perfection of Line and Simplicity of Ornamentation Make for Beauty

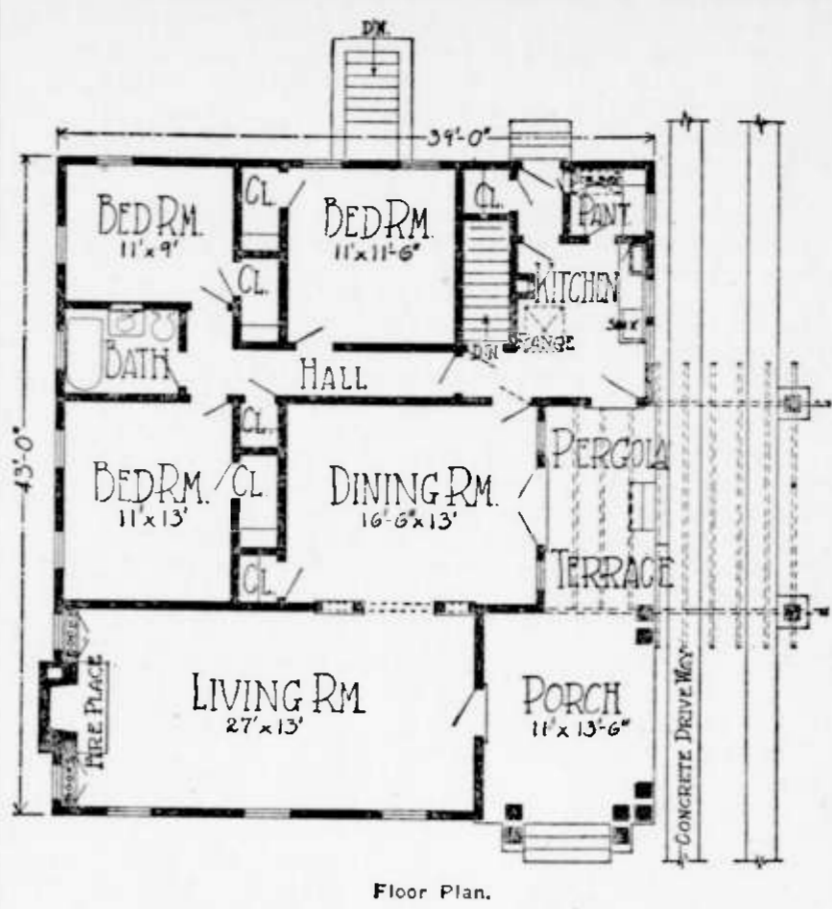

Floor Plan.

By WILLIAM A. RADFORD  
Mr. William A. Radford, architect, has designed a house of 1,200 sq. ft. for a young man. The house is a simple, modern design with a pergola over the porch and a concrete driveway.

The house is a simple, modern design with a pergola over the porch and a concrete driveway. The interior is finished with light-colored wood and has a clean, uncluttered appearance.

Color May Be Used Freely on Sun Porch  
It is well to remember that in the sunroom, color may be freely used in a way not desirable in other parts of the house.

Some Pointers  
Water systems help materially to modernize the old-fashioned building as well as to equip the new one.

Interior Hardware  
The locks on the inner doors of the home are just as deserving of attention and careful selection as those for the outside doors.

High-Grade Stucco Can Be Used at Any Time  
The best stucco can be applied in the winter as well as summer. It is not subject to freezing, and in the winter, when labor is plentiful, it is an ideal time to use this exterior covering.

Breakfast Nook Still Gaining in Popularity  
The breakfast nook continues to gain in popularity, and nowadays few houses of modern design, especially bungalows, are without such a place.

When to Paint  
The best time to paint a house is just before it begins to need it—not after the need is great.

## MRS. WM. BUTTS WAS VERY SICK

Gives Full Credit to Lydia E. Pinkham's Vegetable Compound for Remarkable Recovery

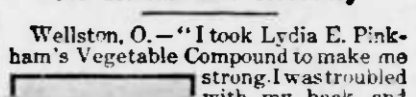

Wellston, O.—"I took Lydia E. Pinkham's Vegetable Compound to make me strong. I was troubled with my back and sides hurting me till I could not do my work and whenever I caught cold it made me irregular. Since I have taken the Compound my side and back don't bother me and I can do my housework and care for my children now, where before I did not feel like doing anything or going around. After my first child was born about four years ago I saw an advertisement in the paper about the Vegetable Compound. I knew it would help me, but I was afraid to try it because people said it would help you to have children and I knew I was having children fast enough. But I thought if it would help me it would be better to have a whole house full of children and have good health. I became stronger from taking it and my husband says I look like a live woman instead of a dead one. When Spring comes I am going to take your Blood Medicine as I am very thin. I will answer letters from any woman who wishes to ask about my medicine."—Mrs. WILLIAM BUTTS, Wellston, Ohio.

### SPOHN'S DISTEMPER COMPOUND

Keep your horses working with "SPOHN'S" Standard Remedy for 32 years for Distemper, Strangles, Influenza, Coughs and Colds. Give to sick and those who are likely to get sick. It is the best remedy for all these ailments. Sold by your druggist. If not, order from Wm. Spohn, 1000 N. Dearborn St., Chicago, Ill.

### MRS. WINSLOW'S SYRUP

For Infants and Children's Coughs  
Children grow healthy and free from colic, diarrhoea, flatulency, constipation and other troubles if given it at the first sign. It is a safe, pleasant, always reliable, non-narcotic and non-toxic remedy. At All Drugstores.

## Gains 20 Pounds

Never knows a sick headache; stomach perfectly well, after taking Beecham's Pills.  
"I have taken Beecham's Pills and NO OTHER MEDICINE with the best results for the past fifteen years. I never take them for sick headaches, from a constipated stomach, and general debility. Now I don't know what a headache is, and my stomach is perfectly well."

## Beecham's Pills

### Don't Cut Out a Shoe Boil, Capped Hoek or Bursitis for ABSORBINE

It will reduce them and leave no blemishes. Stops lameness promptly. Does not blister or remove the hair, and horse can be worked. \$2.50 a bottle delivered. Book 6 A free.

## Yugo-Slavia Water Power

Within the borders of that modern Balkan state, Yugo-Slavia, there are water-power sites available for hydro-electric development which could produce 3,050,000 horse power of electrical energy. Along the Drava river there are sites which could produce approximately 400,000 horse power, while nearly 750,000 horse power of electrical energy could be produced by hydro plants along the Danube.

## Cuticura Soothes Itching Scalp.

On retiring gently rub spots of dandruff and itching with Cuticura Ointment. Next morning shampoo with Cuticura Soap and hot water. Make then your everyday toilet preparations and have a clear skin and soft, white hands.—Advertisement.

## U. S. I Dye King

Before the war Germany supplied 75 per cent of the world demand for dyes; now the United States produces 95 per cent of its domestic needs, England 90 per cent and France, Italy and Japan each 40 to 50 per cent.

## Various Verdicts

"She has a flower-like face."  
"Trifle too lavish with the flour."  
Louisville Courier-Journal.

## From School Teacher to Great Eminence

A young man who was brought up on a farm, qualified for district school teacher, then managed to save enough money to put him thru medical college.

HOME AGAIN  
CHAPTER VII—Continued  
The door opened and Prudence came in. She had a look of surprise on her face. "What a lovely night!" she said. "The moon is just what I needed." Prudence looked at her. "You're just in time," she said. "I was just about to go to bed."

Jerry was going home. He had a look of surprise on his face. "What a lovely night!" he said. "The moon is just what I needed." Prudence looked at him. "You're just in time," she said. "I was just about to go to bed."

Prudence looked at Jerry. "You're just in time," she said. "I was just about to go to bed." Jerry looked at her. "What a lovely night!" he said. "The moon is just what I needed."

## Part Two

CHAPTER I  
The Coming of Jerry  
The morning dawned brightly on the quiet little town of New York. The sun was shining brightly on the water, and the wind was blowing gently from the east.

words that they were warm and bright by the fireplace, with the pine log, and the candles and the candle lights. But in their hearts they were trying to assure themselves that Jerry was a very alert and self-reliant young person who could certainly take care of herself if anybody could, and what childishness to worry!

Jerry was going home. He had a look of surprise on his face. "What a lovely night!" he said. "The moon is just what I needed." Prudence looked at him. "You're just in time," she said. "I was just about to go to bed."

Prudence looked at Jerry. "You're just in time," she said. "I was just about to go to bed." Jerry looked at her. "What a lovely night!" he said. "The moon is just what I needed."

## Plants That Protect Coasts From the Sea

In the struggle to defend our coasts from sea encroachments, seaside authorities have no better allies than the hardy tamarisk and shrubby sea blite. These useful plants are as effective in protecting the lonely stretches of shore as stout sea walls and far-flung groynes, says a writer in London Times. Take, for example, this town on the Sussex coast. This shore was seriously affected by the incoming tides until it was found that the loose shingle that fringes the sea could be bound into a resisting mass by the extensive planting of tamarisk, a hardy little plant whose only real enemy is severe frost.

coming, how it was the last thing in the world she had dreamed of. "But see here," reprimanded Jerry, "you told me all the time she would come back. You said—" Prudence gave him a furious look. "I did not," she declared quite passionately. "Oh, for a visit of course—but to bring all her things and stay forever, I never dreamed of such a thing. I can't tell you how surprised I am!"

Jerry was going home. He had a look of surprise on his face. "What a lovely night!" he said. "The moon is just what I needed." Prudence looked at him. "You're just in time," she said. "I was just about to go to bed."

Prudence looked at Jerry. "You're just in time," she said. "I was just about to go to bed." Jerry looked at her. "What a lovely night!" he said. "The moon is just what I needed."

## There Were Others

The young man hesitatingly entered her father's presence. With a prelude of clearing of the throat and a nervous twitch of his fingers, he said: "I have come to ask you if I may marry your daughter, Gertrude." "You may," said the father, promptly, as he passed the cigars. "And now that you're in the family, may I take you into my confidence?" "Why—er—" exclaimed the happy man.

Jerry let his cigarette go out, lit another feverishly, let it go out again. Prudence held Jerry in a close arm, weeping with her softly. And Jerry talked and on and on, told them of Mimi's pitiful, frivolous life, her wasted motherhood. Sometimes as she talked, she lay in Prudence's lap, crying bitterly, only to sit up again with passionate earnestness to go on with the tragic tale.

Jerry was going home. He had a look of surprise on his face. "What a lovely night!" he said. "The moon is just what I needed." Prudence looked at him. "You're just in time," she said. "I was just about to go to bed."

Prudence looked at Jerry. "You're just in time," she said. "I was just about to go to bed." Jerry looked at her. "What a lovely night!" he said. "The moon is just what I needed."

## Beauty in Cheerfulness

Cheerfulness is almost as necessary as air, food and water. It sits heavily as a pebble thrown into a lake sends ripples to every shore—returning again and again to you—making the heavy load lighter and the dark road brighter for all.—Grit.

Jerry let his cigarette go out, lit another feverishly, let it go out again. Prudence held Jerry in a close arm, weeping with her softly. And Jerry talked and on and on, told them of Mimi's pitiful, frivolous life, her wasted motherhood. Sometimes as she talked, she lay in Prudence's lap, crying bitterly, only to sit up again with passionate earnestness to go on with the tragic tale.

Jerry was going home. He had a look of surprise on his face. "What a lovely night!" he said. "The moon is just what I needed." Prudence looked at him. "You're just in time," she said. "I was just about to go to bed."

Prudence looked at Jerry. "You're just in time," she said. "I was just about to go to bed." Jerry looked at her. "What a lovely night!" he said. "The moon is just what I needed."

## Beauty in Cheerfulness

Cheerfulness is almost as necessary as air, food and water. It sits heavily as a pebble thrown into a lake sends ripples to every shore—returning again and again to you—making the heavy load lighter and the dark road brighter for all.—Grit.

